

## Reading Practice Test 2

---

### READING PASSAGE 1

You should spend about 20 minutes on **Questions 1-13**, which are based on Reading Passage 1 below.



### The Development of Travel under the Ocean

For millennia, humans have been intrigued by what lies beneath the sea and although submarine travel was attempted from time to time, it did not become commonplace until the middle of last century. Several clever and innovative people had experimented with designs for submersible boats before then, but there was much loss of life and little success.

There had long been use of a primitive diving bell for explorative purposes, but it was as a war machine that the submarine came into its own. The first development in the history of American submarines was a small submersible with a hand-cranked screw-like oar and a crew of one. It was built before the American Revolutionary War (1775—1783) but was adapted for use against the British during this war. Although its pilot twice failed to fasten explosive devices to British ships before losing control of his vessel, he escaped harm.

In 1800, an American inventor, Robert Fulton, designed an underwater  
[Access http://ieltonlinetests.com for more practices](http://ieltonlinetests.com)

machine that he called the Nautilus. This version brought in features that can still be found in some modern submarines, notably adjustable diving planes for better underwater manoeuvring, dual systems of propulsion, and a compressed air system that allowed it to stay down for about four hours without surfacing.

Development of submersible vessels lagged a long way behind the continued progress in the design of surface ships until the American Civil War (1861-1865) when both sides tried out various designs. One of those, called the Hunley — named after its financier rather than its inventor, sank twice during training missions with 11 crew members losing their lives including Hunley himself. Notwithstanding these failures, it was commissioned again in 1864 to attack a ship in Charleston Harbor. A torpedo was used to strike and scuttle the ship – a first in naval history, but the submarine never reappeared, and once again the whole crew perished. Its potential had been recognised, but there still remained the challenge of operating safely under the water.

The US Navy could appreciate the strategic benefits of having submarines in its fleet and held a competition to encourage design and construction of these underwater craft. The inventor, John Holland, won the competition and it was his sixth prototype, the Holland, that the navy bought and added to its fleet in 1900. This submarine was quite different from previous designs. It was propelled by a gasoline engine that turned a propeller while the vessel was on the surface. When it submerged, the engine ran a generator to charge batteries to operate an electric motor. The improved propulsion methods were, unfortunately, highly dangerous. Not only is gasoline flammable and unstable, using it in the restricted environment of a submarine posed quite a hazard for the crewmen. There was another problem, too: the batteries were not only heavy, cumbersome and inefficient, but they were also extremely volatile.

During the same period as Holland's efforts were being trialled, a German scientist by the name of Rudolf Diesel created an engine which used a fuel less explosive than gasoline and which could consequently be stored safely. Another advantage was that there was no necessity for an electric spark to ignite the fuel. These safety improvements combined with better fuel economy allowed Diesel engines to power a submarine for longer on the surface; however, batteries were still needed to supply energy for underwater operation.

Although diesel-powered submarines were successful and used by the US Navy for almost 50 years, the search for a single power source carried on. It wasn't long before the concept of nuclear power was realised in Germany and taken

up by an American physicist, Ross Gunn, who could envisage its potential in submersibles. A research team was put together to adapt the concept of nuclear power for use in submarines. In effect, modern nuclear submarines have on board a small nuclear power plant which produces a great amount of energy. This is used to heat water and create steam which drives a huge turbine which turns the propeller.

There have been many adaptations and technological improvements made to submarines over the years, but the shape is basically the same. Obviously, it is a totally enclosed craft, cigar-shaped with narrowed ends. The outer hull is the largest part of the boat and forms the body. The inner hull is designed to resist the considerable water pressure and insulates the crew from the cold. This is where the crew works, eats and sleeps. It also contains the engine room and the apparatus that makes clean air and clean water. Between the hulls are the ballast tanks for controlling buoyancy. There is a tall fin-shaped sail that comes up out of the hull. Inside the sail is the conning tower and extending from this, to the fore, there is a periscope (through which the captain can see the sea and sky when the submarine is near the surface of the water). Sonar is used for navigation deep below the surface. The other projection from the conning tower is the radio antenna.

Underwater, there are two controls for steering the submarine. The rudder (like a tail fin) controls side-to-side movement, and diving planes influence rise and descent. There are two sets of diving planes: the forward sail planes and the stem planes, which are located at the back with the rudder and propeller.

Advancing technology will undoubtedly result in different shapes and modes of operation, and it is quite possible that, in the future, submarines will be manned by robots or computer technology that communicates information to land bases via satellite.

## Questions 1-6

Answer the questions below. Choose **NO MORE THAN THREE WORDS** from the text for each answer.

Write your answers in boxes **1-6** on your answer sheet.

What kind of underwater device was used to investigate the ocean before submersible boats were invented?

1

What was the crewman of the first American-built submarine trying to do before his mission failed?

2 \_\_\_\_\_

What gave the Nautilus the ability to remain submerged for a long time?

3 \_\_\_\_\_

When was a submarine first used successfully to sink an enemy boat?

4 \_\_\_\_\_

What new type of propulsion did the Holland use on top of the water?

5 \_\_\_\_\_

For what reason was Diesel's fuel considered safer than Holland's?

6 \_\_\_\_\_

### Questions 7-13

Label the diagram below. Choose **NO MORE THAN TWO WORDS** from the text for each answer.

Write your answers in boxes **7-13** on your answer sheet.

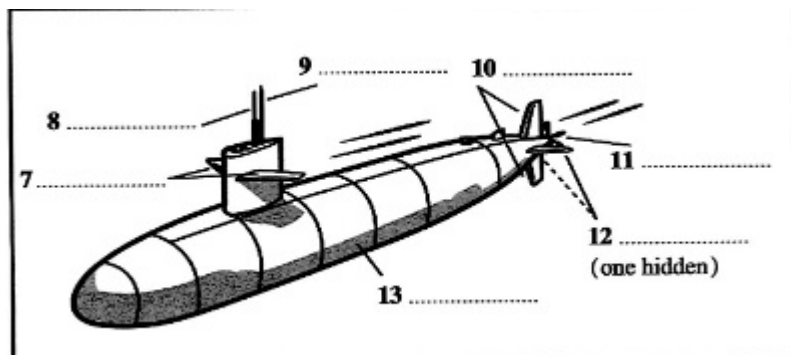

7 \_\_\_\_\_

8 \_\_\_\_\_

9 \_\_\_\_\_

10 \_\_\_\_\_

11 \_\_\_\_\_

12 \_\_\_\_\_

13 \_\_\_\_\_

## READING PASSAGE 2

You should spend about 20 minutes on **Questions 14-26**, which are based on Reading Passage 2 below.



## **Vitamins - To supplement or not?**

Mineral, vitamin, and antioxidant health supplements make up a multi-billion-dollar industry in the United States alone, but do they really work? Evidence suggests supplementation is clearly indicated in special circumstances, but can actually be harmful in others. For the general population, however, supplements have negligible or no impact on the prevention of common cancers, cardiovascular diseases, cognitive decline, mortality, or any other major indicators of health. In pursuit of a longer, happier and healthier life, there are certainly better investments for most people than a tube of vitamin supplements.

Particular sub-groups of the population can gain a proven benefit from supplementation. Folic acid has long been indicated as a prenatal supplement due to its assistance in foetal cell division and corresponding ability to prevent neural tube birth defects. Since Canada and the United States decided to require white flour to be fortified with folic acid, spinal birth defects have plummeted by 75%, and rates of neuroblastoma (a ravaging form of infant cancer) are now 50% lower. In countries without such fortification, or for women on low-carbohydrate diets, a prenatal multivitamin could make the crucial difference. The United States Department of Health and Human Services has concluded that the elderly may also benefit from extra vitamin D; calcium can help prevent bone fractures; and zinc and antioxidants can maintain vision while deflecting macular degeneration in people who would otherwise be likely to develop this affliction.

There is mounting evidence, however, for many people to steer clear of multivitamins. The National Institutes of Health has noted a “disturbing evidence of risk” in tobacco users: beta-carotene, a common ingredient in

multivitamins, was found over a six-year study to significantly contribute to higher lung cancer and mortality rates in smokers. Meanwhile, excessive vitamin A (a supplement often taken to boost the immune system) has been proven to increase women's risk of a hip fracture, and vitamin E, thought to improve cardiovascular health, was contraindicated in a study that demonstrated higher rates of congestive heart failure among such vitamin users. Antioxidant supplementation has no purpose nor does it achieve anything, according to the Food and Nutrition Board of the National Academy of Sciences, and the Medical Letter Group has gone further in suggesting they may interfere with treatment and promote some cancers. Antioxidants are generally regarded as counteracting the destructive effect of free radicals in the body, but according to the Medical Letter's theory, free radicals may also serve the purpose of sending a powerful signal to the body's immune system to fix the damage. By taking supplements, we risk undermining that message and upsetting the balance of antioxidants and free radicals in the body. The supplements counteract the free radicals, the immune system is not placed on alert, and the disease could sneak through the gates.

One problem with supplementation by tablet is the poor record on digestibility. These tablets are often stocked with metal-based minerals that are essentially miniature rocks, and our bodies are unable to digest them. Even the vitamin elements of these pills that are theoretically digestible are often unable to be effectively extracted by our bodies when they arrive in such a condensed form. In Salt Lake City, for example, over 150 gallons of vitamin and mineral pills are retrieved from the sewer filters each month. According to the physician's desk reference, only about 10% - 20% of multivitamins are absorbed by the body. The National Advisory Board is even more damning, suggesting that every 100mg of tablet corresponds to about 8.3mg of blood concentration, although noting that this can still potentially perform a helpful role in some cases. In effect, for every \$100 you spend on vitamin supplements, over \$90 of that is quite literally flushed down the toilet.

A final argument against multivitamins is the notion that they can lead people - consciously or not - to the conclusion that supplementation fills in the gaps of an unhealthy diet and mops up afterwards, leaving their bodies none the wiser that instead of preparing a breakfast of fresh fruit and muesli, they popped a tiny capsule with coffee and a chocolate bar. In a seven-year study, however, the Heart Protection study did not find any positive outcome whatsoever from multivitamins and concluded that while vitamins in the diet are important, multivitamin tablets are safe but completely useless. There is evidently no shortcut around the task of buying, preparing, and consuming fresh fruit and

vegetables every day. Boosting, supplementing, and fortifying products alter people's very perception of what healthy food is; instead of heading for the fresh produce aisle in the supermarket, they are likely to seek out sugary, processed foods with a handful of extra B vitamins as a healthy choice. We cannot supplement our way out of a bad diet.

## Questions 14-16

Choose, the correct letter, **A**, **B**, **C**, or **D**.

Write the correct letters in boxes **14-16** on your answer sheet.

14 The writer does not recommend multivitamin supplementation for \_\_\_\_

- A**  pregnant women.
- B**  young children.
- C**  anyone prone to eye problems.
- D**  old people.

According to the writer, vitamin E has been shown  
15 to \_\_\_\_

- A**  lead to heart problems.
- B**  be good for heart health.
- C**  support the immune system.
- D**  have no effect.

16 The Medical letter Group believes antioxidant supplementation \_\_\_\_

- A**  is ineffective in attacking free radicals.
- B**  alerts the immune system to the presence of free radicals.
- C**  attacks both free radicals and the immune system.
- D**  prevents the immune system from responding to free radicals.

## Questions 17-21

Do the following statements agree with the information given in Reading Passage 2?

In boxes **17-21** on your answer sheet, write

<b>YES</b>	if the statement agrees with the views of the writer
<b>NO</b>	if the statement contradicts the views of the writer
<b>NOT GIVEN</b>	if it is impossible to say what the writer thinks about this

17   Some multivitamin tablets have indigestible ingredients.

18   Some individual vitamins are better absorbed than others in a tablet form.

19   Our bodies cannot distinguish food-based from supplement-based vitamins.

20   Multivitamins can lead to poorer overall eating habits in a person's life.

21   People typically know that fortified processed foods are not good for them.

### Questions 22-26

*Classify the following groups of people according to whether they believe*  
*Write the correct letter **A**, **B** or **C**, in boxes **22-26** on your answer sheet.*

<b>A</b>	the supplementation may have a positive effect
<b>B</b>	the supplementation may have a negative effect
<b>C</b>	supplementation has no effect

22   The United States Department of Health and Human Services

23   The National Institutes of Health

24   The Food and Nutrition Board of the National Academy of Sciences

25   The National Advisory Board

26   The Heart Protection Group



# READING PASSAGE 3

You should spend about 20 minutes on **Questions 27-40**, which are based on Reading Passage 3 below.



## The Birth of Suburbia

**A.** There is no single pivotal moment that could be separated out from any other as the conception of the suburban lifestyle; from the early 1800s, various types of suburban development have sprung up and evolved in their own localised ways, from the streetcar suburbs of New York to the dormitory towns outside of London. It is William Levitt, however, who is generally regarded as the father of modern suburbia. During World War II, Levitt served in the United States Navy where he developed expertise in the mass construction of military housing, a process that he streamlined using uniform and interchangeable parts. In 1947, the budding developer used this utilitarian knowledge to begin work with his father and architect brother constructing a planned community on Long Island, New York. With an emphasis on speed, efficiency, and cost-effective production, the Levitts were soon able to produce over 30 units a day.

**B.** William Levitt correctly predicted the demand for affordable, private, quiet, and comfortable homes from returning GIs after World War II and with the baby boom starting to kick in. All the original lots sold out in a matter of days, and by 1951, nearly 18,000 homes in the area had been constructed by the Levitt family company. Levittown quickly became the prototype of mass-produced housing, spurring the construction of similar projects in Pennsylvania, New Jersey, and even Puerto Rico, followed by a new industry, and soon a new way of life and a new ideal for the American family.

**C.** One of the major criticisms of suburbia is that it can lead to isolation and social dislocation. With properties spread out over great swathes of land, sealed off from one another by bushes, fences and trees, the emphasis of suburban life is placed squarely on privacy rather than community. In the

densely populated urban settlements that predated suburbs (and that are still the predominant way of life for some people), activities such as childcare and household chores as well as sources of emotional and moral support were widely socialised. This insured that any one family would be able to draw on a pool of social resources from their neighbours, building cohabitants and family on nearby streets. Suburbia breaks these networks down into individual and nuclear family units resulting in an increase in anti social behaviour even amongst the wealthy. Teens from wealthy suburban families, for example, are more likely to smoke, drink alcohol, and use drugs than their poorer urban peers, and are also more likely to experience depression and anxiety.

**D** . Another major problem with the suburban lifestyle is its damaging ecological impact. The comparison of leafy, quiet, and low-density suburbs with life in the concrete towers of sooty, congested urban conurbations is actually quite misleading; as it turns out, if you want to be kind to the natural environment, the key is to stay away from it. Suburbia fails the environmental friendliness test on a number of counts. Firstly, due to their low population density, suburbs consume natural land at a much higher rate than high-density row housing or apartment buildings. Secondly, they encourage the use of personal motor vehicles, often at a rate of one per family member, at the expense of public transport. It is also much less efficient to provide electricity and water to individual suburban houses instead of individual units in an apartment building. In his comparison of urban and suburban pollution, Edward L. Glaeser concluded that we need to “build more sky towers – especially in California”. Virtually everywhere, he found cities to be cleaner than suburbs. And the difference in carbon dioxide emissions between high-density cities and their suburbs (for example, in New York) was the highest. Urban residents of New York can claim on average to produce nearly 15,000 pounds of carbon dioxide less than their suburban peers.

**E**. Another negative aspect of suburban life is its stifling conformity and monotony of social experience. It was not just the nuts and bolts and the concrete foundations of suburban houses that got replicated street upon street, block upon block, and suburb upon suburb; it was everything from the shops and cultural life to people’s hopes, dreams, and aspirations. Suburbia gave birth to the “strip mall”, a retail establishment that is typically composed of a collection of national or global chain stores, all stocked with a centrally dictated, homogenous array of products. The isolation and lack of interaction in suburbs has also encouraged the popularity of television, a passively receptive medium for the viewer that, in the early days at least, offered an extremely limited scope of cultural exposure compared with the wealth of experiences

available in the inner city. Meanwhile, much of the inner-city “public sphere” has been lost with suburban flight. The public sphere is the area of social life in which people come together to freely discuss and identify social problems. In the city, this has traditionally occurred around newsstands, in coffee houses, salons, theatres, meeting halls, and so on. Suburbia has not found a way to replace this special type of social experience, however. Social meeting points in the suburbs tend to be based exclusively around specific interests such as sports or cultural clubs, with no broad forms of daily social interaction.





**F.** These points do not suggest the idea of suburbia itself is flawed, but that it has not been executed in a way that takes into account the full spectrum of human needs and desires. This likely reflects the hasty, thrown-together nature of early suburban development. With the baby boom rippling across Western countries and demand for family-friendly housing skyrocketing, developers and city planners were unable to develop sophisticated models. Now, however, we should take time to consider what has gone wrong and how we can reconfigure the suburb. How can we imbue suburban life with the lost sphere of public discussion and debate? How can people maintain their sought after privacy without sacrificing a sense of community? How can we use new technologies to make suburbs environmentally friendly? These are questions for which the developers of tomorrow will have to find answers, lest the dream of suburbia become the nightmare of disturbia.

## Questions 27-31

*Reading Passage 3 has six paragraphs, A-F.*

*Which paragraph contains the following information?*

*Write the correct letter, A-F, in boxes 27-31 on your answer sheet.*

- 27   A reason to construct taller buildings
- 28   Where people might discuss issues of societal concern in urban locations
- 29   The founder of what is broadly understood as contemporary ‘suburbs’
- 30   Examples of problems suffered by the youth that suburban lifestyle can make worse
- 31   A model for suburban development in the latter half of

the 20th century

## Questions 32-38

Do the following statements agree with the information given in Reading Passage 3?

In boxes **32-38** on your answer sheet, write

<b>YES</b>	if the statement agrees with the views of the writer
<b>NO</b>	if the statement contradicts the views of the writer
<b>NOT GIVEN</b>	if it is impossible to say what the writer thinks about this

32   A good principle for ecological preservation is to avoid human interference.

33   In some countries, suburbs are more environmentally friendly than in the USA.

34   Suburban development fosters the use of both public and private forms of transport

35   People cannot relate to each other in suburbs because their lives are too different.

36   There is not much variety amongst the goods at a strip mall.

37   Television has not tended to offer the same diversity as urban cultural outlets.

38   There are numerous of ways of communication and interaction between people living in the suburbs.

## Questions 39-40

Choose **TWO** letters, **A-E**.

Write your answers in boxes **39-40** on your answer sheet.

Which **TWO** of the following does the author conclude?

- A**  The very concept of a healthy suburban lifestyle is problematic.

- B**  The speed of suburban growth has contributed to its imperfections.
- C**  By thinking about human and ecological needs, suburbs can become better places to live.
- D**  Developers will have to think about ways of living that do not require suburbs.
- E**  Suburbs have their downsides, but they are the best way for parents to raise children.

 **Solution:**

- |           |                         |           |                           |
|-----------|-------------------------|-----------|---------------------------|
| <b>1</b>  | (primitive) diving bell | <b>2</b>  | fasten explosive devices  |
| <b>3</b>  | compressed air (system) | <b>4</b>  | 1864                      |
| <b>5</b>  | gasoline (engine)       | <b>6</b>  | less explosive / volatile |
| <b>7</b>  | sail planes             | <b>8</b>  | periscope                 |
| <b>9</b>  | radio antenna           | <b>10</b> | rudder                    |
| <b>11</b> | propeller               | <b>12</b> | stem planes               |
| <b>13</b> | outer hull              | <b>14</b> | A                         |
| <b>15</b> | A                       | <b>16</b> | D                         |
| <b>17</b> | YES                     | <b>18</b> | NOT GIVEN                 |
| <b>19</b> | NOT GIVEN               | <b>20</b> | YES                       |
| <b>21</b> | NO                      | <b>22</b> | A                         |
| <b>23</b> | B                       | <b>24</b> | C                         |
| <b>25</b> | A                       | <b>26</b> | C                         |
| <b>27</b> | D                       | <b>28</b> | E                         |
| <b>29</b> | A                       | <b>30</b> | C                         |
| <b>31</b> | B                       | <b>32</b> | YES                       |
| <b>33</b> | NOT GIVEN               | <b>34</b> | NO                        |
| <b>35</b> | NO                      | <b>36</b> | YES                       |
| <b>37</b> | YES                     | <b>38</b> | NO                        |
| <b>39</b> | B,C                     |           |                           |
| <b>40</b> |                         |           |                           |